

≡ B 8C I 6H5 G?

B: CFA 8F5K B; C:: 7 9C: 9FFC FG

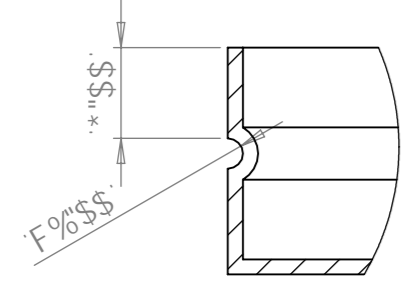
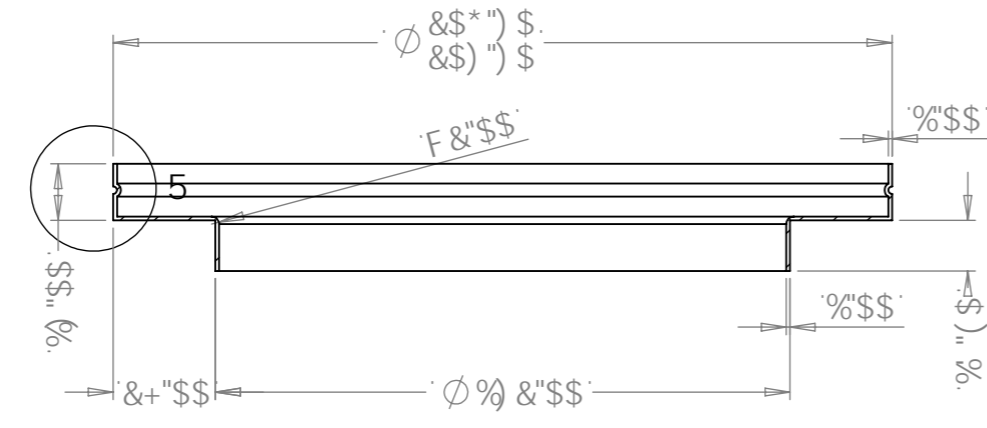

8 9H5 @5
G7 5 @9 % & . %

G97 HC B 5!5
G7 5 @9 % &

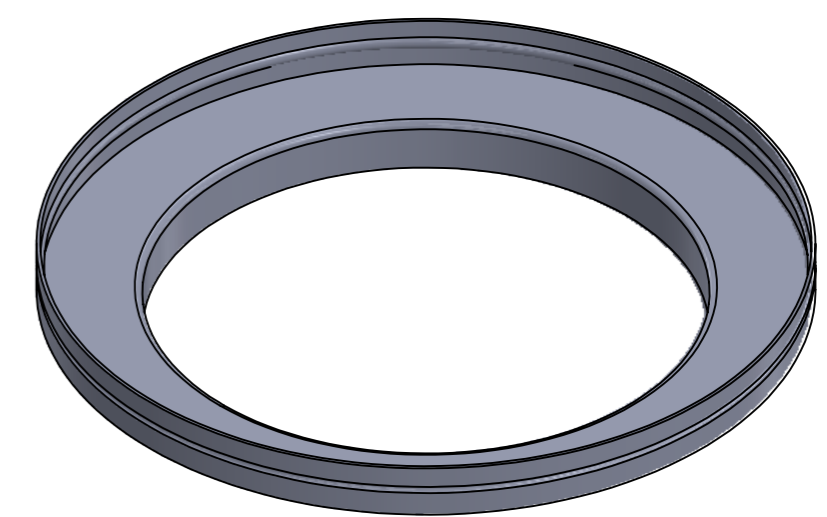
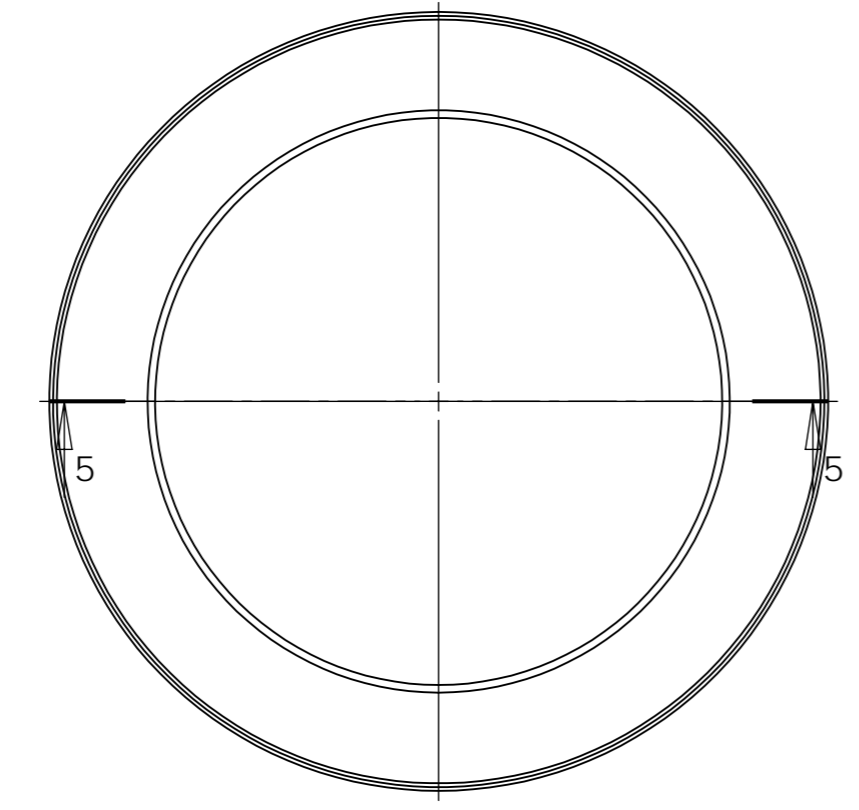

5bcX]hYX DUfhBi a VYf. F\$%G9* & ' '

DfcXi Wh]cb. G]a cb: UffYb
7cg]b[. G]a cb: UffYb

GG 9	8 9G7 F DHC B	B H5 @G	97 "B" Bc	85H9	5 @8 A 9BG€ BG B A @A 9HFG	F9A CJ 95 @6 FFG 5B8 G-5FD98: 9G 1 B @GGC H-9FK 69 G5H98	FYj Yfj] @a]hX l b]h&7 \UbX YfgFck 7c WYgYf 9ggYl 7C %&<; \$%&\$* : ****' k k k "fyj Yfj] "hX"i _	8F5K B	5DD	D5FHBT A 69F	F \$%G9* & ' &	
%	CF ≡ B5 @GG 9	6A	% (#\$%#&\$%)	HC @9F5B7 9Gf5H&\$7 l1 B @GGC H-9FK 69 G5H98	BCA B5 @B95F 8 A 9BG€ BG	<C @GHC 6C) \$\$ % .) * H: F958GHC 6G * (% . % A 9H 7 7 C I F G? 6GD H: F958GHC 6G & ++ A 98 : H		6A	85H9	H H @9	&\$*!%) &a a '<][\ : `ck : UH5XUdHYf	
				CJ 9F1B7 @ OS \$\$\$ \$\$\$	G F: 57 9 : B G< 9G A @B: : B, H FB B: : B+ : F B B B: : B*						A 5HF 5 @ 5`cm	
				SI & \$\$ Z# '\$) \$ Z# '\$%)	5B: 8 A G Z# '\$) fi						BGD97 HC B @J 9@	D5FHET 5 @#M: F589
				&) SI % \$\$\$ Z# % \$\$\$ Z# '\$ 8\$							8F: "BC"	F \$%G9* & ' &!H
				% \$\$\$ D @ G Z# & \$\$\$ Z# '\$ \$								